



## ***Ethernet/IP Module***

***for Kollmorgen S200, S300, S600, S700 & AKD™ Servo Drives***

# Table of Contents

1. Part Numbers.....	1
2. Installation Instructions.....	1
2.1 AKD Module Installation .....	2
3. Hardware Overview .....	2
Cabinet Mounting Changes.....	2
4. Hardware & Electrical Overview.....	3
5. Setting IP Address of a Module.....	4
6. CAN Baud Rate & Address.....	5
7. Installing the Electronic Data Sheet Files (EDS) .....	5
8. Adding the Module to an RSLogix 5000 project .....	6
9. Using the IMAC Provided Add-on Instructions Blocks .....	8
10. Using the Provided User-Defined Data Types EIP_Input & EIP_Output.....	8
Appendix A - Technical Overview.....	9
Module Functionality & Register Mapping .....	9
Customization.....	9
Appendix B – Single Page Quick Start Guide for the Advanced PLC User.....	10
Appendix C – Contacting IMAC Motion Control.....	11
Technical Support .....	11
Warranty Information.....	11
Appendix D – Compatible Rockwell Automation Controllers .....	11

Document Version	Description
1.0 – Dec 10 <sup>th</sup> , 2009	Initial Release
1.1 – Dec 14 <sup>th</sup> , 2009	Cosmetic changes, grammar, corrected mounting requirements.
1.2 – Dec 22 <sup>nd</sup> , 2009	Added required CAN Address for communication.
1.3 – Apr 21 <sup>st</sup> , 2010	Added detailed AKD installation requirements.

## 1. Part Numbers

Servo Drive Series	Ethernet/IP Module	Description
Kollmorgen AKD-Pxxxxx-xxCN	EIP-AKD-00	Module with 1 RJ45 port, single axis interface, RJ12 connection, top mounted.
Kollmorgen S300, S600, S700	EIP-S3-00	Module with 1 RJ45 port, single axis interface, DB9 connection with RS-232 breakout, top mounted.
Kollmorgen S200-CNS	EIP-S2-00	Module with 1 RJ45 port, single axis interface, 5 pin Phoenix Contact connection, face mounted.

## 2. Installation Instructions

Fasten the module to the CAN connector on the drive as shown in the images below. You can still communicate to the drive via RS-232 ASCII (S300, S600, S700), RS-232 Modbus RTU (S200) or Ethernet Telnet (AKD) while the module is installed.



S200-CNS & EIP-S2-00



S300 & EIP-S3-00



AKD & EIP-AKD-00

## 2.1 AKD Module Installation

The EIP-AKD-00 module attaches to the drive's case with a pair of self tapping screws, installed by the user.

1. Place the module on the top surface of the drive, adjacent to the drive's X11 / X12 / X13 receptacles. Position the module so that it's front face is flush with the front face of the drive.
2. Align the module's right side mounting tab hole with the far right side of a preexisting grill slot and insert a 8-16 x 1/4" screw, tighten 1 turn only.
3. Then line up the rear mounting tab with a preexisting grill slot so that the module is straight on the top surface of the drive and insert a 8-16 x 1/4" screw, tighten 1 turn only.
4. Slowly tighten each screw until screw head makes contact with mounting tabs and stop. **DO NOT OVER TIGHTEN.**
5. Insert module phone jack (RJ-11) plug into the drive's X12 or X13 CANopen receptacle.

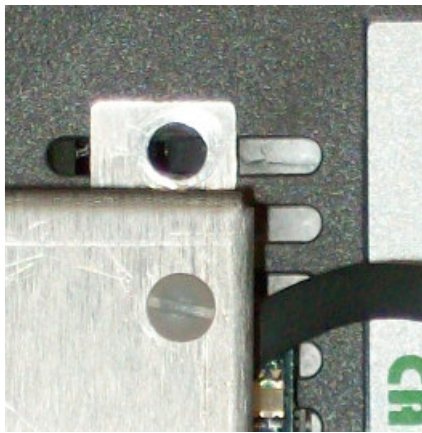

## 3. Hardware Overview

Drive Platform	Connector Location	Drive Connector Type
Kollmorgen AKD	X12 – Top, Front-most RJ12	RJ12 Connection
Kollmorgen S200	J12 – Front, Lower Left	Phoenix Contact 5 Pin
Kollmorgen S300	X6 – Top, Front-most	Male 9 Pin D-Sub, RS-232 Breakout Provided
Kollmorgen S600	X6 – Top, Front-most	Male 9 Pin D-Sub, RS-232 Breakout Provided
Kollmorgen S700	X6 – Top, Front-most	Male 9 Pin D-Sub, RS-232 Breakout Provided

### Cabinet Mounting Changes

<b>Kollmorgen AKD</b>	Adds 1.00 inches to height and 0.375 inches to width on 3 & 6 Amp 240 volt models. Adds 1.00 inches to height on other models.
<b>Kollmorgen S200</b>	<b>3 &amp; 6 Amp AC Models:</b> Side to side clearance increases to 1.25 inches. <b>All models:</b> Depth increases 1.25 inches
<b>Kollmorgen S300, S700</b>	None. Adds 1.55 inches to height. Feedback connector w/ bend radius is taller.
<b>Kollmorgen S600</b>	None. Adds 1.35 inches to height. Feedback connector w/ bend radius is taller.

## 4. Hardware & Electrical Overview

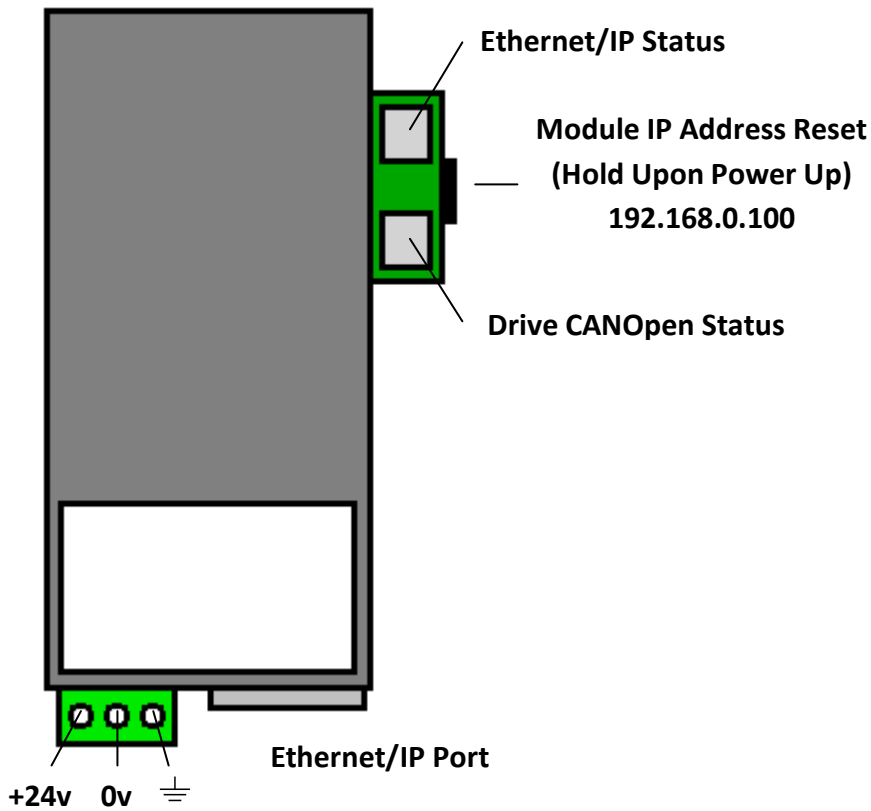

LED	Color	State	Indicates
Ethernet/IP	None	Off	No Power / No Ethernet Link
	Red	Solid	Unrecoverable Fault
		Flashing	Recoverable Fault or I/O Connection Timed Out
	Green	Solid	Normal Operation
		Flashing	Device is Idle or not allocated to a PLC
Red/Green	Alternating	Self Test / IP Address will be set to 192.168.0.100 upon power cycle	
CANOpen	None	Off	No Power
	Red	Solid	No CANOpen Communication
		Flashing	CANOpen Stopped state
	Green	Solid	Normal Operation
		Flashing	CANOpen Pre-operational State
Red/Green	Alternating	Self Test / IP Address will be set to 192.168.0.100 upon power cycle	

<b>Input Voltage</b>	20-28 VDC
<b>Power Draw</b>	3 W

## 5. Setting IP Address of a Module

The default IP Address of every module is 192.168.0.100, with a subnet mask of 255.255.255.0. The default subnet mask means that the module can only connect to a PC or PLC that has an IP address with identical first 3 numbers.

Set your PC's IP address to be 192.168.0.XXX, where XXX is a value between 0 and 255 (but not 100, as that is the IP address of each module). Make sure this isn't an IP address of another device on your network, or you'll have an IP addressing conflict. You can connect to the module directly with a CAT 5 Ethernet patch cable, through a router, or through a switch.

With the module powered, open an internet browser such as Internet Explorer or Firefox and go to address <http://192.168.0.100>. The module has a dedicated web server that will present a welcome screen, where you can set a permanent static IP address, subnet mask, and default gateway.

### Resetting the Module's IP Address

If you can't connect to the module, it's possible that another user of the device has changed the IP address. Turn on the module while holding the S1 button and you should see both sets of lights alternating red/green. Cycling the power again will reset the module to its default with an IP address of 192.168.0.100. On the network screen, set your module's new static IP address. Press the Apply button and cycle the 24 volt power to the module for the changes to take effect.

The screenshot displays the web interface for the IMAC EtherNet/IP Module. On the left, there is a navigation menu with three buttons: "Network Setup", "Firmware Download", and "www.imac-mcc.com". The main content area features the "imac motion control" logo and the text "IMAC EtherNet/IP Module - Version 1.1.04". Below this, the "Network Settings" section lists the current configuration: MAC Address (00:18:C7:01:04:11), IP Address (192.168.1.100), Subnet Mask (255.255.254.0), and Gateway Address (192.168.0.1). A "Network Setup" section provides input fields for these three parameters, all of which are currently filled with the same values as shown in the settings section. At the bottom of the form are "Apply" and "Cancel" buttons. A reminder at the very bottom states: "REMEMBER: Cycle power on the unit for changes to take effect!"

## 6. CAN Baud Rate & Address

The EIP Module has a default CAN baud rate of **500 kBaud** and looks to communicate to CAN **Address 1**. These are the default baud rate and address of the S300, S600 and S700 drive.

The AKD drive has its CAN baud rate at a default of 125 kBaud. This can be changed using the FBUS.PARAM1 parameter on the drive and setting it equal to 500. The dials on the front dictate the CANOpen address. Set these to be address 1.

The S200 drive has its CAN baud rate at a default of 1000 kBaud. This can be changed using the S13 dip switches on the top of the drive. By flipping the first dip switch to the down position, the baud rate will be set to 500 kBaud. The dials on the front dictate the CANOpen address. Set these to be address 1.

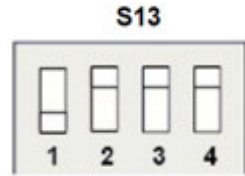

## 7. Installing the Electronic Data Sheet Files (EDS)

Installing an EDS file allows the Ethernet/IP Module to be identified by Rockwell's RSLinx software. The installation procedure is straightforward.

1. From the computer's desktop, click Start > Programs > Rockwell Software > RSLinx Tools > EDS Hardware Installation Tool.  
This will execute the EDS Hardware Installation Tool software.
2. From the Rockwell Software - Hardware Installation Tool dialog box, click Add.
3. From the Rockwell Software's EDS Wizard, click Register a directory of EDS files.
4. The folder path should appear on the In folder: bar.
5. Click Next.
6. The software will run the files through a test that evaluates the EDS files for errors.
7. The test results should display a "green check mark" to the left of the EDS file.
8. Click Next.
9. The installation tool may ask if you want to Change Graphic Image?  
If the icon is in the same directory, it will find it.
10. Click Next.
11. This will bring up the Final Task Summary.
12. Click Next.
13. Once the "Please wait as the EDS wizard installs the new files..." message goes away, you have successfully completed the registration of the EDS files.
14. Click Finish.

Close the Rockwell Software - Hardware Installation Tool dialog box by clicking Exit.

## 8. Adding the Module to an RSLogix 5000 project

To add the module to a Rockwell Automation PLC, follow the steps below. **Remember: The IP address of the module must be set before proceeding!** The module will show up within RSLinx if you installed its EDS file.

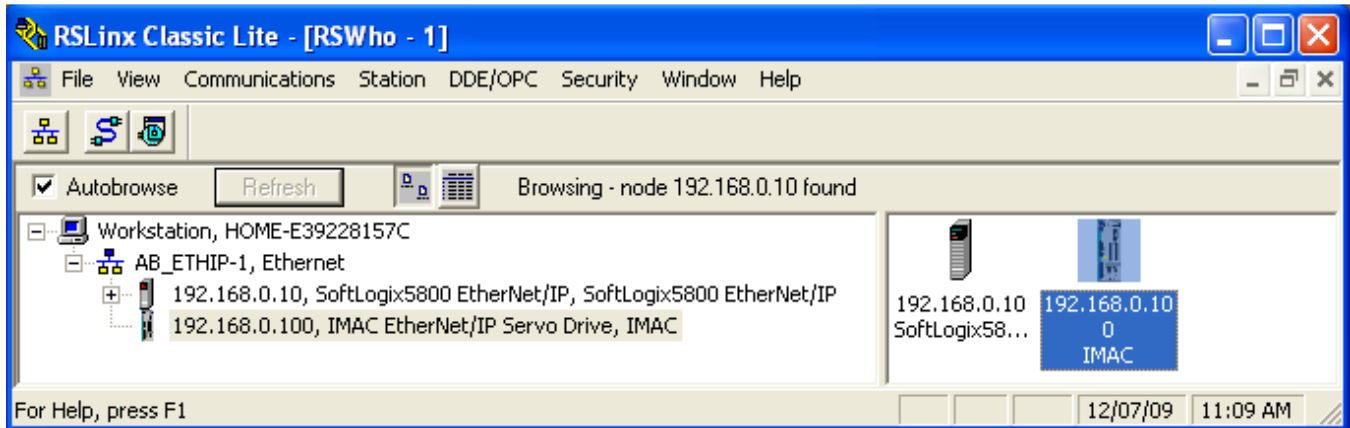

To properly setup the module, within **the I/O Configuration** of your project, find the PLC's **backplane**, and then go to the slot of your **EtherNet/IP** module. Under **Ethernet** and then add.

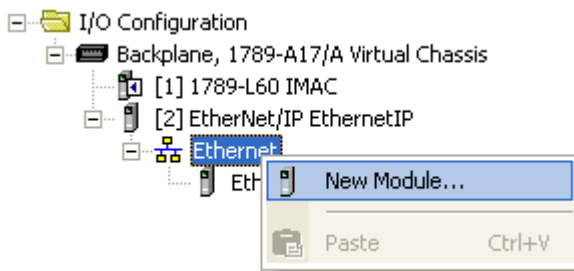

Under **Communications**, select an **ETHERNET-MODULE (Generic Ethernet Module)** and press **OK**.

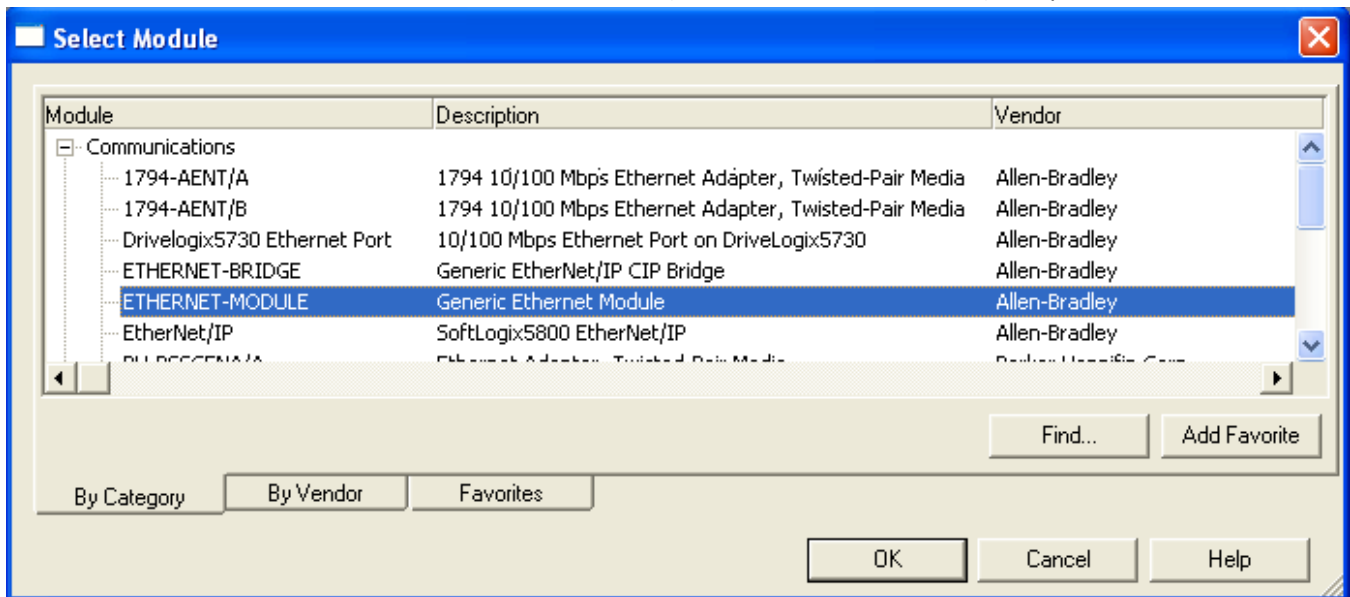

Copy the **Connection Parameters** and **Comm Format** from the image below. Here you'll enter the IP Address you setup through the module's embedded webserver. Under generic Ethernet/IP module configure the connection parameter and ensure the **Comm Format** is DINT

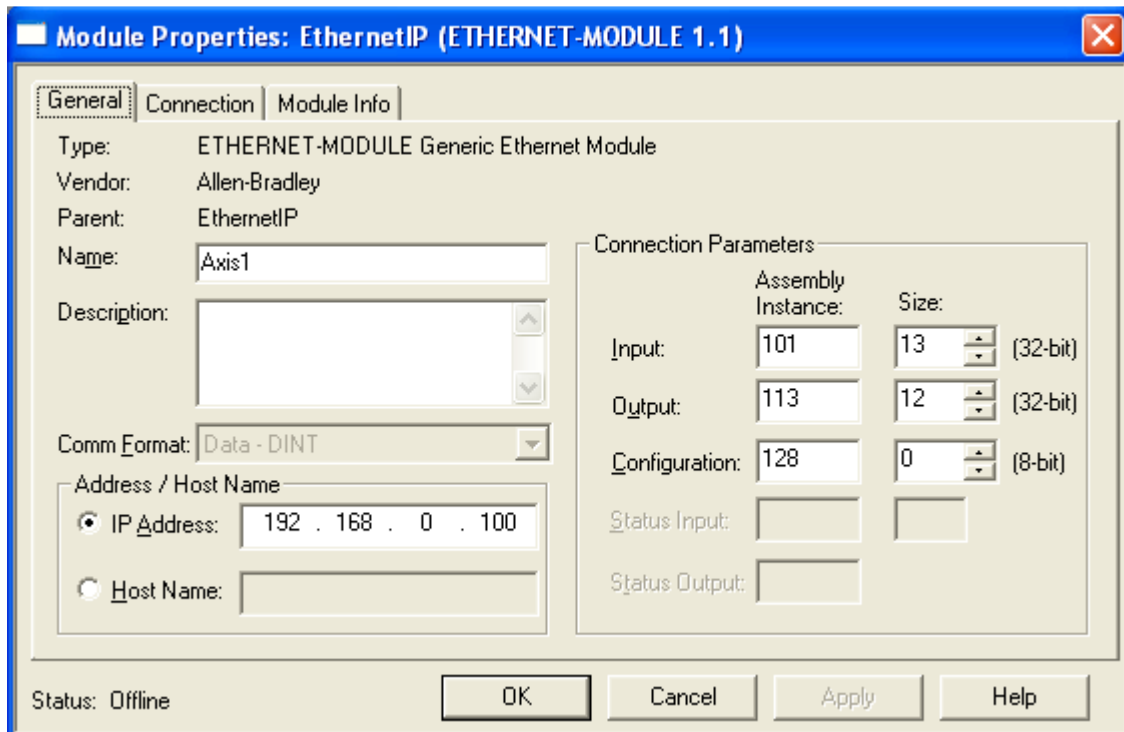

On the Connection Tab, set the Requested Packet Interval to 5ms.

**IMAC Add-on Instructions are designed around an RPI of 5 ms.**

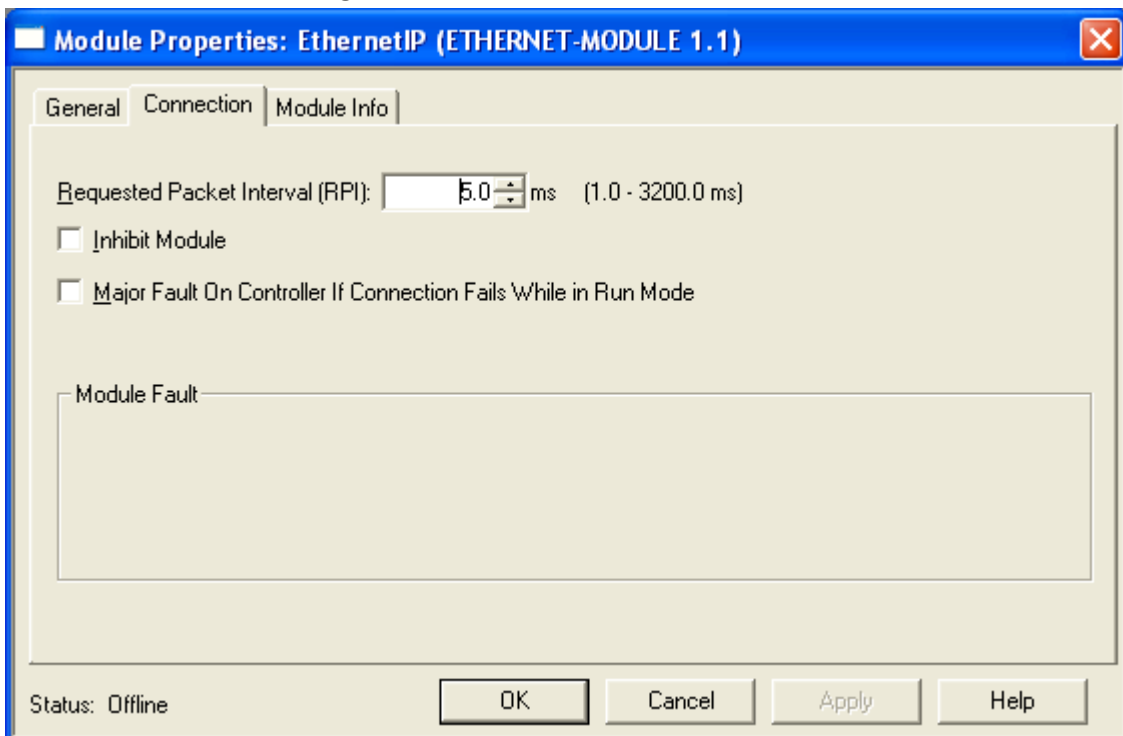

## 9. Using the IMAC Provided Add-on Instructions Blocks

To add on the speed of developing your motion control projects, IMAC has created and provides add-on instructions to use in your RSLogix 5000 projects, as well as user defined data types to ensure that your projects are easy to understand, troubleshoot and edit. Each instruction has detailed, built-in help and documentation.

There are 12 add-on instructions that have been created. Move\_Jog, Move\_Home, Move\_Absolute, Move\_Relative, Drive\_Configure, Drive\_Status, Drive\_Read & Drive\_Write.

Add-On Instruction Name(s)	Functional Description
<b>Move_Home</b>	Homes the motor using the specified homing method selected in the instruction with a defined speed and same acceleration & deceleration rate.
<b>Move_Jog</b>	Moves the motor at a specified rate until power is removed from the Instruction. Homing is required before using this instruction.
<b>Move_Relative</b>	Moves the motor a specified distance from its present position at a specific acceleration, speed and deceleration rate. Power should be kept to the instruction until the movement is complete. Homing is required before using this instruction.
<b>Move_Absolute</b>	Moves the motor to a specified absolute position at a specific acceleration, speed and deceleration rate. Power should be kept to the instruction until the movement is finished. Homing is required before using this instruction.
<b>Axis_Setup_AKD</b> <b>Axis_Setup_S200</b> <b>Axis_Setup_S300</b>	Needs to be run at the start of the program for each axis. This configures the polled I/O from the drive that will be available for the other add on instructions.
<b>Axis_Status_AKD</b> <b>Axis_Status_S200</b> <b>Axis_Status_S300</b>	Provides information about the drive, including its enable state, digital I/O, fault & warning codes, home status, moving, ready to move, etc. Can be run continuously.
<b>Axis_Read / Axis_Write</b>	Allows for any parameter with a CANOpen address to be read or written to. Takes approximately 40 ms to execute. Desired data at higher speed should be mapped to a CAN Open PDO. Contact IMAC for further details.

## 10. Using the Provided User-Defined Data Types EIP\_Input & EIP\_Output

All IMAC supplied Add-on instructions assume that the Axis I/O data is in the user-defined data types EIP\_IN and EIP\_OUT. The examples below use *Axis1In* and *Axis1Out* as variables with the EIP\_Input and EIP\_Output data type. These two variables are then placed in the AxisIn and AxisOut inputs of each IMAC add-on instruction. There needs to be a set of these copy commands for each module used!

Expected Placement in Code	Instruction
<b>Before</b> any IMAC created add-on instructions are called. Must be executed every scan.	<pre> COP Copy File Source Axis1:I.Data[0] Dest Axis1In Length 1 </pre>
<b>After</b> any IMAC created add-on instructions are called. Must be executed every scan.	<pre> COP Copy File Source Axis1Out Dest Axis1:O.Data[0] Length 48 </pre>

## Appendix A - Technical Overview

### Module Functionality & Register Mapping

The Ethernet/IP module is an application focused CAN-Open to Ethernet/IP bus coupler that utilizes a combination of standard and manufacturer registers that are transferred over Ethernet/IP Polled I/O. These registers are detailed below. **They are mapped automatically with the Axis Setup instructions.**

		Byte 3	Byte 2	Byte 1	Byte 0
Bytes		Bits 31...24	Bits 23...16	Bits 15...8	Bits 7...0
3...0	O.Data[0]	Reserved	Reserved	Rescan PDO	Target CAN State
7...4	O.Data[1]	Position	Position	Position	Position
11...8	O.Data[2]	Velocity	Velocity	Velocity	Velocity
15...12	O.Data[3]	Acceleration	Acceleration	Acceleration	Acceleration
19...16	O.Data[4]	Deceleration	Deceleration	Deceleration	Deceleration
23...20	O.Data[5]	Unused	Unused	Unused	Unused
27...24	O.Data[6]	Unused	Unused	Unused	Unused
31...28	O.Data[7]	O_C	O_C	Motion Task	Motion Task
35...31	O.Data[8]	--	Opmode	Control Word	Control Word
39...36	O.Data[9]	Timeout (0-255ms)	Req. Type	SDO Seq #	SDO Seq #
43...40	O.Data[10]	SDO Data Size	SDO Sub Index	SDO Index	SDO Index
47...44	O.Data[11]	SDO Write Data	SDO Write Data	SDO Write Data	SDO Write Data

		Byte 3	Byte 2	Byte 1	Byte 0
Bytes		Bits 31...24	Bits 23...16	Bits 15...8	Bits 7...0
3...0	I.Data[0]	N/A	N/A	CAN Status	CAN Status
7...4	I.Data[1]	Mfg. Drive Status	Mfg. Drive Status	Mfg. Drive Status	Mfg. Drive Status
11...8	I.Data[2]	FREE	Operating Mode	Status Word	Status Word
15...12	I.Data[3]	Position	Position	Position	Position
19...16	I.Data[4]	Velocity	Velocity	Velocity	Velocity
23...20	I.Data[5]	Current MT	Current MT	Warnings	Warnings
27...24	I.Data[6]	Unused	Unused	Unused	Unused
31...28	I.Data[7]	Unused	Unused	Unused	Unused
35...31	I.Data[8]	Unused	Unused	Unused	Unused
39...36	I.Data[9]	Reserved	Echo Req. Type	Echo SDO Seq #	Echo SDO Seq #
43...40	I.Data[10]	SDO Data Size	SDO Sub Index	SDO Index	SDO Index
47...44	I.Data[11]	SDO Read Data	SDO Read Data	SDO Read Data	SDO Read Data
51...48	I.Data[12]	SDO Error	SDO Error	SDO Error	SDO Error

### Customization

All Kollmorgen drives are flexible to have additional or different registers mapped for your specific application and it is possible to have IMAC create custom instructions that map these differently for you. Please contact IMAC Motion Control to discuss your application requirements.

## Appendix B – Single Page Quick Start Guide for the Advanced PLC User

1. Power up the module with 24 Vdc and connect it and your PC to a your managed switch.
2. Set your PC's IP address to be 192.168.0.1
3. Open up a web browser and go to <http://192.168.0.100>. Set the module to the desired static IP address.
4. Cycle power to the module & verify new IP address by connecting to its address with your web browser.
5. Install the electronic data sheet (imac-eip.eds) with *RSLinx EDS Hardware Installation Tool*
6. Open RSLinx and verify the module shows up at the address set in step 3.
7. In your RSLogix5000 project, go to the Ethernet/IP module you have on your PLC and go to the Ethernet subheading. Add a ETHERNET-MODULE (Generic Ethernet Module)
8. Configure the module with the IP specified in step 3;
  - a. *General Tab*: Provide a module **name** (e.g. Axis1), **Input Assembly Instance 101** – **Size 13**, **Output Assembly Instance 113** – **Size 12**
  - b. *Connection Tab*: Set the **RPI** to be 5 ms.
9. Import the User Defined Data Types EIP\_IN and EIP\_OUT to your project.
10. Import the Add-on instructions for your specific drive model.
11. Import an example program section.
12. Verify you have a solid green LED when the module is connected to the drive and both have power. If not, ensure the CANOpen baud rate is 500 kBaud and cycle power to the drive and module.
13. Provide power to the Axis\_Setup block. When it is completed, it's done (DN) bit should start the Axis\_Status block.
14. Use other Move and Home add-on instructions as needed.

## Appendix C – Contacting IMAC Motion Control

### Technical Support

IMAC Motion Control has application engineers on staff to provide technical support to assist with the integration of our Ethernet/IP modules into your applications. Our technical support hours are 8 AM to 4:30 PM, Monday through Friday, excluding US federal holidays.

We can be contacted via phone at 847.741.4622 or through email at [ethernet-ip@imac-mcc.com](mailto:ethernet-ip@imac-mcc.com)

A dedicated website is available with the latest module manuals, example codes, custom add on instructions and firmware at <http://www.imac-mcc.com/ethernet-ip>

### Warranty Information

IMAC Motion Control stands behind our products. We warrant all of our modules to be free of defects in workmanship and components for the period of one year.

## Appendix D – Compatible Rockwell Automation Controllers

The IMAC Ethernet/IP module is only compatible with the following Rockwell Automation PLCs:

1. *ControlLogix™*
2. *CompactLogix™*
3. *SoftLogix™*

The modules are not compatible with the *MicroLogix™* series of PLCs or any PLC that does not support Add-on Instructions and 32 bit integers. Please contact IMAC technical support for further details.